

NKOSITHANDILEB SOLAR

Tunisia grid-connected inverters are supplied in large quantities

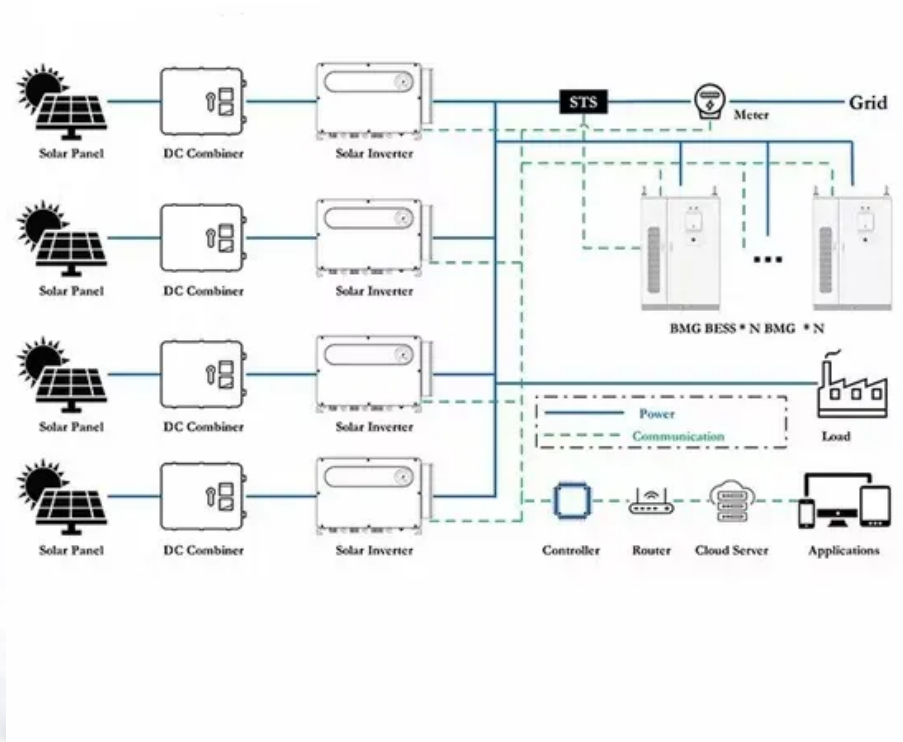

Overview

Does Tunisia have a power grid?

Tunisia's national grid is connected to those of Algeria and Libya which together helped supply about 12% of Tunisia's power consumption in the first half of 2023. Moreover, in August 2023, Tunisia's sub-sea connection project with Italy, called ELMED, was approved for \$337 million funding from the European Commission.

How much power does Tunisia produce?

Tunisia has a current power production capacity of 5,944 megawatts (MW) installed in 25 power plants, which produced 19,520 gigawatt hours in 2022. State power utility company STEG controls 92.1% of the country's installed power production capacity and produces 83.5% of the electricity.

What are Tunisia's energy projects?

One third of the projects will be for wind farms and two thirds for solar photovoltaics. Tunisia's national grid is connected to those of Algeria and Libya which together helped supply about 12% of Tunisia's power consumption in the first half of 2023.

Who produces electricity in Tunisia?

State power utility company STEG controls 92.1% of the country's installed power production capacity and produces 83.5% of the electricity. The remainder is imported from Algeria and Libya as well as produced by Tunisia's only independent power producer (IPP) Carthage Power Company (CPC), a 471-MW combined-cycle power plant.

Tunisia grid-connected inverters are supplied in large quantities

Tunisia's national grid is connected to those of Algeria and Libya which together helped supply about 12% of Tunisia's power consumption in the first half of 2023. Moreover, in August 2023, Tunisia's sub-sea connection project with Italy, called ELMED, was approved for \$337 million funding from the European Commission.

Tunisia has a current power production capacity of 5,944 megawatts (MW) installed in 25 power plants, which produced 19,520 gigawatt hours in 2022. State power utility company STEG controls 92.1% of the country's installed power production capacity and produces 83.5% of the electricity.

One third of the projects will be for wind farms and two thirds for solar photovoltaics. Tunisia's national grid is connected to those of Algeria and Libya which together helped supply about 12% of Tunisia's power consumption in the first half of 2023.

State power utility company STEG controls 92.1% of the country's installed power production capacity and produces 83.5% of the electricity. The remainder is imported from Algeria and Libya as well as produced by Tunisia's only independent power producer (IPP) Carthage Power Company (CPC), a 471-MW combined-cycle power plant.

Grid-connected inverters play a pivotal role in integrating renewable energy sources into modern power systems. However, the presence of unbalanced grid conditions poses ...

Wholesale Off-Grid Inverters PV System? An off-grid solar system, also known as off-the-grid or standalone, is a photovoltaic system that has no access to the utility grid. For ...

This review article presents a comprehensive review on the grid-connected PV systems. A wide spectrum of different classifications ...

Buy Wholesale Grid-Tie Inverters for PV Systems? Simply put, a grid-tie inverter converts direct current (DC) into alternating current (AC) suitable for injecting into an electrical power grid, ...

Where is the first large scale solar power plant in Tunisia? The first large scale solar power plant of a 10MW capacity, co-financed by KfW and NIF (Neighbourhood Investment Facility) and ...

This research explores the incorporation of initial capital limitations into the design and optimization of grid-connected photovoltaic (PV) systems, ...

Summary: Tunisia is rapidly expanding its renewable energy infrastructure, driving demand for grid-connected inverters. This article explores the applications, market trends, and ...

A large number of populations of the world; especially in developing countries; are living in rural or remote areas those are geographically isolated from the grid connection.

Grid-connected inverters are key components of distributed generation systems (DGSs) and micro-grids (MGs), because they are effective interfaces for renewable and ...

This study aims to raise awareness of renewable energies' importance from an economic and environmental perspective and provide reference data for the investment ...

This study aims to raise awareness of renewable energies' importance from an economic and environmental perspective and provide reference data for the investment ...

This review provides a comprehensive overview of the research efforts focused on investigating the stability of PV grid-connected inverters that operate under weak grid conditions.

Tunisia grid-connected inverters are supplied in large quantities Tunisia's power sector is well developed, and nearly the entire population enjoys access to the national electricity grid. ...

The control of grid-connected inverters has attracted tremendous attention from researchers in recent times. The challenges in the grid connection of inverters are greater as ...

Overview Tunisia's power sector is well developed, and nearly the entire population enjoys access to the national electricity grid. Tunisia has a current power production capacity ...

The Tunisian government says concession and authorization frameworks are advancing multiple PV projects, while new entrants including SoleCrypt plan additional plants, ...

The main aim of the research work presented in this paper consists of proposing an effective control scheme for a grid-connected ...

Tunisia Inverter Market Overview Tunisia`s inverter market is expanding with applications in renewable energy systems, HVAC equipment, and industrial automation, focusing on energy ...

In grid-connected photovoltaic systems, a key consideration in the design and operation of inverters is how to achieve high efficiency with power output for different power ...

The distribution network located in the state of Hammam-Lif which is in the north of Tunisia near the Mediterranean coast, having a PV penetration of 12 MW was studied. A large-scale PV ...

The first issue focuses on the MG modeling in the case of three connected inverters to

the utility grid; these inverters are based on LCL filters with different inductive and ...

Tunisia's national grid is connected to those of Algeria and Libya which together helped supply about 12% of Tunisia's power consumption in the first half of 2023. Moreover, in ...

Contact Us

For catalog requests, pricing, or partnerships, please contact:

NKOSITHANDILEB SOLAR

Phone: +27-11-934-5771

Email: info@nkosithandileb.co.za

Website: <https://nkosithandileb.co.za>

Scan QR code to visit our website:

